



CAI.42 15/16

Challenge and
Improvement Committee

22nd February 2016

E

Subject: Update from the Democracy Working Group

Report by:

Monitoring Officer
Alan Robinson

Contact Officer:

Nicola Calver
Governance and Civic Officer
Nicola.calver@west-lindey.gov.uk
01427 676606

Purpose / Summary:

To provide Members with an update on the work of the Democracy Working Group, including reporting on the recent chamber reconfiguration trials and proposing a terms of reference for the group.

RECOMMENDATION(S):

That Members:

- i) Consider and note the work to date of the Democracy Working Group and request a further update in six months;**
- ii) Note and approve the four year plan;**
- iii) Make recommendations to the forthcoming meeting of Council to adopt a new configuration for Council meetings; and**
- iv) Accept and confirm the terms of reference for the DWG.**

IMPLICATIONS

Legal: None

Financial : FIN REF 130/16

A £2000 pressure had been identified for undertaking modifications to the chamber to accommodate a horse shoe layout.

The 18th Birthday Card initiative was initially withdrawn due to budget pressures, reinstating this will have implications of up to £500.

Flags for Schools will be funded from Community Grant which is deemed adequate for this function.

Staffing :None

Equality and Diversity including Human Rights : None

Risk Assessment :None

Climate Related Risks and Opportunities :None

Title and Location of any Background Papers used in the preparation of this report:

None

Call in and Urgency:

Is the decision one which Rule 14.7 of the Scrutiny Procedure Rules apply?

i.e. is the report exempt from being called in due to urgency (in consultation with C&I chairman)

Yes

No

X

Key Decision:

A matter which affects two or more wards, or has significant financial implications

Yes

No

X

1. BACKGROUND

- 1.1 The Democracy Working Group (DWG) last reported to Challenge and Improvement Committee (C&I) on 1st September 2015, where it was requested for a further report to be submitted in 6 months updating on progress.
- 1.2 The priorities agreed were as follows:
- Revisiting options for a reconfiguration of the Council Chamber to support in-meeting communication and debate;
 - Development of a four-year plan for promotion of democracy and youth engagement through the civic office; and
 - Use of communication and social media to publicise and engage with our communities around democracy.
- 1.3 Since that meeting, the DWG have met twice, once on 23rd September and again on 1st February – dates that strategically bracketed the Reconfiguration of the Council Chamber Project.

2. PROGRESS MADE TO DATE

- 2.1 Along with the reconfiguration of the chamber and developing a four-year plan, as set out later in this report, the DWG have been progressing the following initiatives to promote democracy and youth engagement within the District:
- Continued attendance and support of the Road Safety Partnership, which will be brought forward for update at their next meeting;
 - Letters agreed to be circulated to West Lindsey Primary Schools inviting them to hold their School Council meetings in the Chamber at the Guildhall and meet with the Chairman;
 - Letters agreed to be circulated on a rolling basis to all Secondary schools within the District for the Chairman and Ward Members to visit to talk to students about democracy and the decision making process.
 - A new card will be designed to send out to new voters on their 18th Birthday;
 - Funding will be made available and publicised through the community grant for schools to purchase flag poles and be involved in flag raising days for the district;
 - Support for the Clean for the Queen project;
 - Screens have been installed in the Council Chamber for better viewing for the public during meetings, and to display the webcast feed.
- 2.2 As an item of note, a new microphone system, to replace the faulty and obsolete Beyer conferencing equipment, has been installed this week and training will be rolled out shortly.

3. FOUR YEAR PLAN

3.1 The DWG have been clear in their objectives and have developed a four year plan as requested to stagger the work of the group over the four-year term meeting the priorities set. This plan is as follows:

CIVIC YEAR	PRIORITY 1	PRIORITY 2	PRIORITY 3
15/16	Reconfiguration of the Council Chamber to aid debate and democratic process	Reintroduction of 18 th Birthday Cards for new voters	Road Safety Partnership attendance and support
16/17	Reintroduction and development of Primary Youth Council Meetings in the Chamber	Commence Secondary School Visits for all Members of Council	Flags and Flagpoles for Schools Initiative
17/18	Introduction of Youth Chairman and Youth Council for WL	Focus on Scouting / Guiding	Focus on Cadets and Introduce a Chairman's Cadet
18/19	Youth Council to lead on projects such as a Takeover		

3.2 Further, the DWG are helping the Community Awards Panel to deliver the active competition for schools to design the WLDC birthday card to the Queen on her 90th Birthday.

3.3 The current Chairman is continuing to visit schools around the district during the 15/16 civic year, accompanied by ward members.

3.4 The DWG welcome the views of all Members of Council on matters relating to democracy and youth engagement and there is an open invitation for attendance at their meetings (16th March at 10am), or ideas can be fed back through C&I Chairs Briefing or by email to Members of the Group (Cllrs Welburn, Patterson and McNeill, with the Chairman as a consultee)

3.5 Challenge and Improvement Committee are asked to consider the proposed work plan, and agree for 6 monthly monitoring.

4. RECONFIGURATION OF THE COUNCIL CHAMBER

4.1 Following much debate at the Member Forum (which comprises a cross section of all political groups) the DWG took on the task of reconfiguring the Council Chamber to deliver a better opportunity for debate and to aid the Democratic process.

- 4.2 During the previous civic year, this process had been discussed and a scoping exercise completed, which formed a solid basis to begin development of layouts that would fulfil the criteria set, but also work within the limitations of the room.
- 4.3 These limitations included:
- Remaining in the front section of the chamber only, due to camera positions (Immovable);
 - the positioning of the presentation screens (Immovable)
 - the positioning of the TV monitors (immovable)
 - the positioning of the floor boxes (£200 to move each)
 - using the existing furniture (£400 per unit)
 - ensuring the space could remain flexible for all other current uses
 - seating for 34 Members on the floor, 2 on the dais
 - seating for 6 officers, with room for 2 additional people at Annual Council
 - Mindful of the IT equipment installed
 - Mindful of the plumbed in drinks fountain
- 4.4 Four options were drawn up and circulated to members of the DWG, facilities and democratic staff, and all were invited to attend a morning dedicated to putting each design in to practice.
- 4.5 These options were discussed and scrutinised prior to recommending trialling 2 options for the meetings of Council on 15th November 15 and 25th January 16. These are set out at Appendix A and B to this report.
- 4.6 Seating arrangements were proposed to group leaders prior to each meeting, on the basis that the temporary plans would not reflect a confirmed seating chart on adoption – this would be negotiated between the groups and take into account individual requirements.
- 4.7 Feedback was sought from all Members of Council directly after both layout trials, and this information was collated and presented to the DWG at their meeting on 1st February.
- 4.8 A summary of comments received is set out below:
- 15th November (Option 1)
- Cost concerns at a time when funds should be conserved;
 - Open Layout offers good view of Members' faces to each other;
 - Situation of the Leader of the Opposition and Administration Members;
 - Reduced view of the monitor screens;
 - Temperature of the room;
 - Better view for the public;
 - Individual requirements for seating;

- A blind spot for the Vice Chairman to note Members who wished to speak;
- Power provision.

25th January (Option 2)

- The previous layout was preferred;
- Issues around the location of the Leader of the Opposition and Opposition Members;
- Welcomed the room temperature;
- View of dais was a difficult angle for some positions;
- Cost concerns at a time when funds should be conserved;
- Individual requirements for seating;
- Free movement and space concerns

4.9 The scoring received showed a strong indication that Members preferred Option 1 (15th November) to both the Option 2 (25th January) and the original layouts.

AVERAGE SCORES		
	OPTION 1	OPTION 2
Appropriate for purpose	7.3	5.0
Aids Debate / Democracy	7.0	5.3
Comfortable / Accessible	6.9	6.2
Ease of viewing presentations	7.5	4.4
Percentage of Cllrs preferring Option	63%	52%

4.10 The DWG considered each comment made, and the scores received and favoured recommendation of Option 1 for adoption.

4.11 C&I Committee should be mindful that each option presented also has a cost implication of £1200 - £1900, to move floor boxes and relocate the drinks machine. Therefore a £2000 pressure has been identified to undertake this unbudgeted work.

4.12 The Committee are asked to reflect on the findings of the DWG and make recommendations, where appropriate, to Council for the adoption of a new layout from Annual Council on 9th May.

5. TERMS OF REFERENCE

5.1 At its initial meeting, the DWG pulled together a list of outcomes to be achieved over the lifetime of the group. These have been pulled together into a Terms of Reference for agreement by C&I Committee.

5.2 Further, discussion has taken place at previous meetings of the Committee in providing a forum for civic matters to be discussed and debated, and this report suggests incorporation of that subject in to the remit of the DWG.

5.3 Terms of Reference – Democracy Working Group

a) Membership 2015/16

The Membership of the DWG is appointed at Annual Council.

- Cllr Roger Patterson
- Cllr Anne Welburn
- Cllr Giles McNeill

Consulting on Civic Matters:

- The Chairman of the Council
- Chairman of Challenge and Improvement Committee

All Members of Council are welcome to feed in to the discussions of the group.

b) Purpose

The purpose of the Democracy Working Group is to:

- Increase confidence in local democracy – getting more people involved and taking responsibility for their community.
- Increase the public's awareness of the democratic process
- Increase awareness of the role of councillors.
- Help the public to understand the difference they could make as a councillor.
- Increase the number of people putting themselves forward to be a Parish / District councillor.
- Increase the voting turnout.
- Involve young people (Youth Councils / schools / etc) in the democratic process.
- Be a sounding board for civic matters as and when referred to the group.

c) Role

- The DWG works together as a close knit team to provide leadership on progression of initiatives to meet the objectives of the group.
- The DWG brings together and represents all Members of Council in the promotion of democracy.

d) Responsibilities

The DWG take collective responsibility for:

- Engaging all Members in the work it undertakes;
- Reporting on a regular basis and when requested to its parent committee (Challenge and Improvement);
- Developing ideas to further its objectives;
- Making recommendations, where necessary to its parent committee.

e) Modes of Operation

- The Group tailors its ways of working to its various functions;
- The Group meets on a regular basis, as business progression dictates.
- Agendas and Minutes are produced for each meeting, and Minutes are provided to the parent committee on a regular basis by email.

APPENDIX A

38
Director

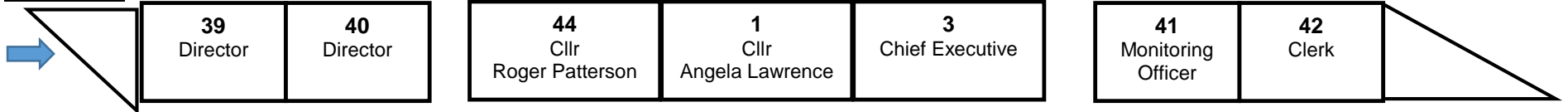

43
Officer

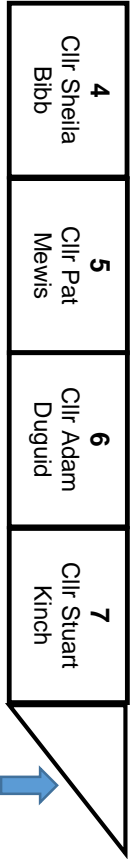

8 Cllr Steve England

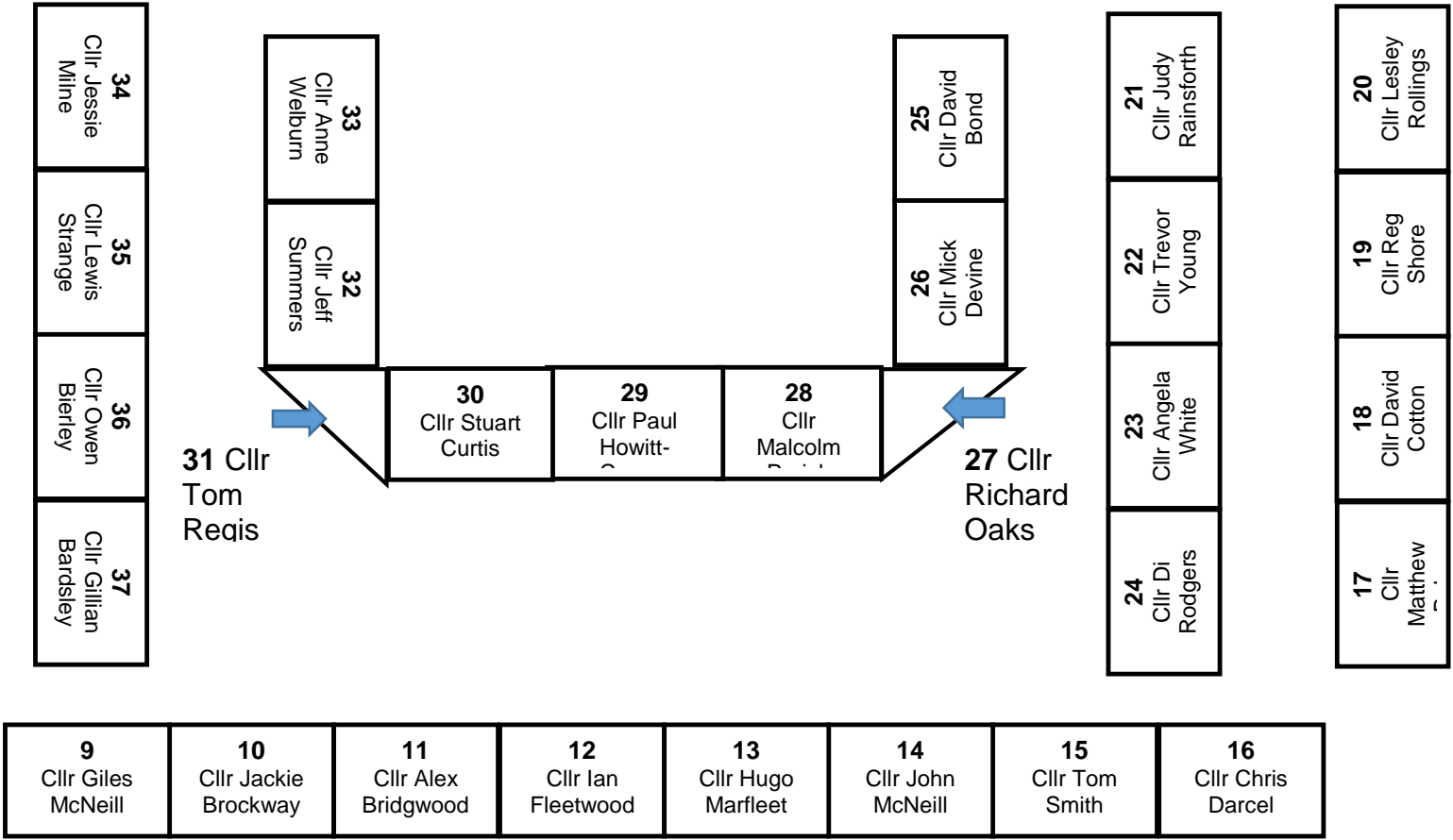

APPENDIX B

CRF

DOO

Roger Patterson	Angela Lawrence	CEX
-----------------	-----------------	-----

Officer	Director	Director	Director	Clerk	MO
---------	----------	----------	----------	-------	----

W-ZZDOO

W-ZZDOO

Alex Bridgwood	Adam Duguid	Pat Mewis	Malcolm Parish	Steve England	Ian Fleetwood	Gill Bardsley	Lewis Strange
----------------	-------------	-----------	----------------	---------------	---------------	---------------	---------------

Giles McNeill	Jeff Summers	Anne Welburn	Tom Regis	Stuart Curtis	Owen Bierley
---------------	--------------	--------------	-----------	---------------	--------------

David Cotton	Reg Shore	Lesley Rollings	Richard Oaks	David Bond	Mick Devine
--------------	-----------	-----------------	--------------	------------	-------------

Di Rodgers	Angela White	Matthew Boles	Judy Rainsford	Trevor Young	Chris Darcel	Jackie Brockway	Hugo Marfleet
------------	--------------	---------------	----------------	--------------	--------------	-----------------	---------------

P-CBLL-C

P-CBLL-C

Stuart Kinch	Sheila Bibb	Jessie Milne	Paul H-Cowan	John McNeill	Thomas Smith
--------------	-------------	--------------	--------------	--------------	--------------

DOO

